



Features

- Single coil latching power relay
- UL F class rated standard
- Heavy contact load, strong shock and vibration resistance
- UL/CUL certified

Contact Data*

Contact Arrangement	1A = SPST 1C = SPDT	Contact Rating N.O.	30A @ 277VAC resistive, 6k cycles 25C ambient 40A @ 277VAC resistive, 6k cycles 25C ambient 50A @ 277VAC resistive, 6k cycles 25C ambient
Contact Resistance	< 50 milliohms initial	N.C.	30A @ 277VAC resistive, 6k cycles 25C ambient 40A @ 277VAC resistive, 6k cycles 25C ambient 50A @ 277VAC resistive, 6k cycles 25C ambient
Contact Material	AgSnO ₂ , AgSnO ₂ In ₂ O ₃		
Maximum Switching Power	13850VA, 1500W		
Maximum Switching Voltage	277VAC, 110VDC		
Maximum Switching Current	50A		

Coil Data Single Coil Latching*

Coil Voltage VDC		Coil Resistance Ω +/- 10%		Pick Up Voltage VDC (max) 80% of rated voltage	Pulse Magnitude ms	Coil Power W	Operate Time ms	Reset Time ms
Rated	Max	.9W	1.5W					
5	6.0	28	16.7	4.0	≥100	.9 1.5	15	15
12	14.4	160	96	9.6				
24	28.8	640	384	19.2				
48	57.6	2560	1536	38.4				

General Data*

Electrical Life @ rated load	50K cycles, average	
Mechanical Life	1M cycles, average	
Insulation Resistance	1000 Ω min. @ 500VDC initial	
Dielectric Strength	Coil to Contact	2500V rms min. @ sea level initial
	Contact to Contact	1500V rms min. @ sea level initial
Shock Resistance	200m/s ² for 11 ms	
Vibration Resistance	1.50mm double amplitude 10~40Hz	
Operating Temperature	-55°C to +125°C	
Storage Temperature	-55°C to +155°C	
Solderability	270°C for 5 s	
Weight	28g, 20g (no cover)	

* Values can change due to the switching frequency, desired reliability levels, environmental conditions and in-rush load levels. It is recommended to test actual load conditions for the application. It is the user's responsibility to determine the performance suitability for their specific application. The use of any coil voltage less than the rated coil voltage may compromise the operation of the relay.

L115F2

Ordering Information

1. Series	L115F2	1C		M	12VDC	S	.9
L115F2							
2. Contact Arrangement							
1A = SPST							
1C = SPDT							
3. Profile							
Blank = Standard							
L = Low Profile							
4. Contact Rating							
M = 30A							
K = 40A							
H = 50A							
5. Coil Voltage							
5VDC							
12VDC							
24VDC							
48VDC							
6. Sealing Options							
S = Sealed, standard							
7. Coil Power							
.9 = .9W **for 30A and 40A contacts only							
1.5 = 1.5W **for 50A contacts only							
8. Contact Material							
Blank = AgSnO ₂							
U = AgSnO ₂ In ₂ O ₃							

L115F2

Dimensions

Units = mm

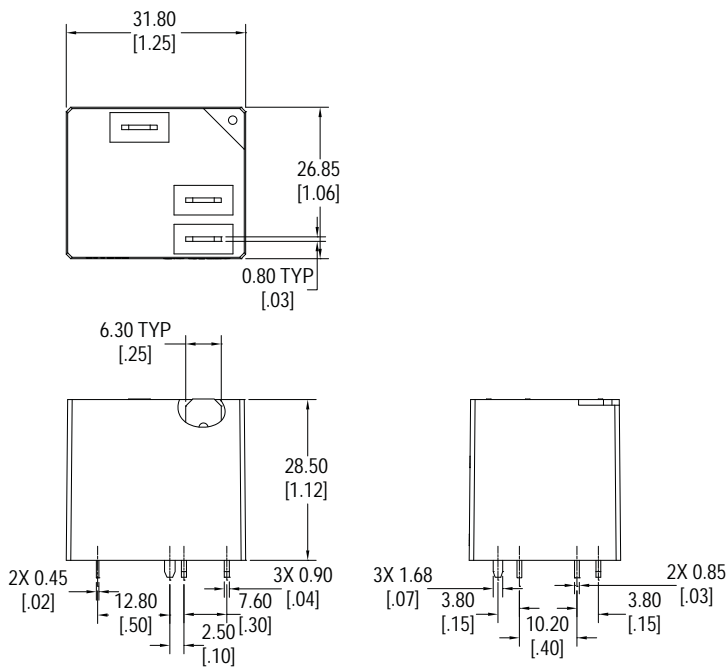

Standard

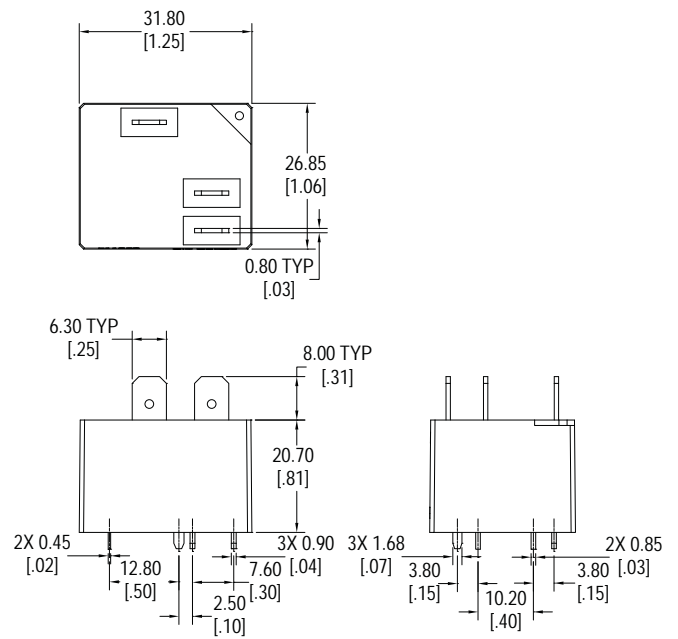

Low Profile

Schematics & PC Layouts

Bottom Views

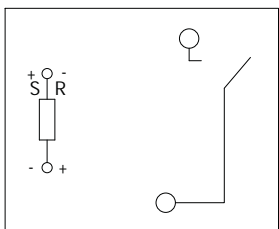

1A

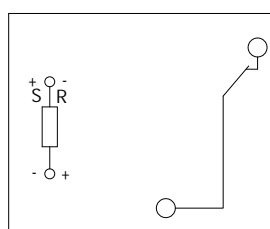

1B

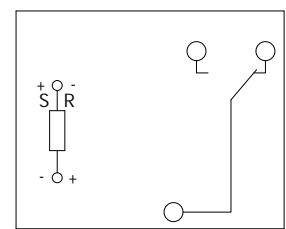

1C

